



MXL Cr-24

Vocal & Instrument

Studio Condenser Microphone Kit

Marshall Electronics, Inc.
1910 East Maple Ave. El Segundo, CA 90245
Phone: (310) 333-0606 Fax: (310) 333-0688
E-mail: Sales@mxlmics.com
Internet: www.MXLmics.com

Thank you for purchasing the MXL Cr-24 Vocal & Instrument Studio Condenser Microphone Kit. With proper care, this microphone kit will provide many years of satisfaction. For best results, please take a few moments to review this literature.

General Characteristics

These microphones have gold-sputtered diaphragms and a fixed cardioid pickup pattern. Condenser microphones are very sensitive, readily revealing very subtle sonic details. They also tend to pick up sounds outside the pattern more than some designs, which can lead to powerful feedback if you are not careful. We strongly advise experimentation with placement and isolation requirements with the gain initially set low to avoid equipment (and hearing) damage. It is also strongly advised to use a mesh pop-filter to avoid moisture from damaging the capsule.

Power Requirements

IMPORTANT: These units require phantom power at 48 volts, +/- 4 volts. Each unit has been thoroughly checked before shipping, so if you do not hear sound, check that the phantom power on your mixer or separate power supply is switched on!

-10dB Pad & Bass Roll-off Switch

Your Cr-24 Large Capsule Condenser Microphone includes a -10dB pad and bass roll-off switch. The -10dB pad allows this microphone to be used in very loud sonic environments without significant distortion. If you hear distortion from the microphone, engage the “-10dB pad” on the back of the microphone to the -10dB position. You may also move the microphone farther away from the sound source.

The Cr-24 also includes a bass roll-off switch to help reduce proximity effect. Proximity effect is distortion that often occurs when a sound source is too close to the mic. Some microphone patterns boost bass as you get closer to the microphone; cardioid mics, for instance, tend to boost bass. The bass roll-off switch reduces the low frequencies for a more full range sound.

Shockmount

The high isolation shockmounts may shift during shipping. Simply shift the elastic bands to center the microphone in the assembly. Be sure that the wire clamp does not rest on the chassis of the mount, as this impairs mechanical isolation. Slide the mount all the way to the rim of the microphone grill for the most secure hold. To attach the mics to the shockmounts, follow these instructions:

Microphone Cables

These microphones connect to a mixer or preamp via XLR cable (not included). The microphone cable can have a profound effect on the sound of any microphone. Even the finest microphones will sound poor if the interconnect cable allows noise to enter, or causes distortion and loss of information. Use only the best microphone cable your budget will allow. We recommend Mogami cable for the best results.

Care

Dust and foreign material can degrade the performance of a microphone over time so always store the unit in its case. For vocals closer than 3”, use a “popper stopper” or the included foam windscreens to avoid getting moisture on the diaphragm as this can substantially degrade the microphones’ performance. Store the microphones in the flight case in a cool, dry place along with the included packet of silica gel. When the mics are not in use or stored in the flight case, we recommend using the included leatherette pouches for extra protection. We’ve even included handling gloves to avoid finger prints on your new Cr-24 microphones. These steps will help keep the mics in proper working order for many years to come.



Specifications

MXL Cr-24 Large Capsule Condenser Microphone

Type:	Pressure gradient condenser mic
Diaphragm:	3-micron gold sputtered
Frequency Range:	20Hz - 20kHz
Polar Pattern:	Cardioid
Sensitivity:	-42.9 dB re 1 V/Pa
Impedance:	200 ohms
S/N Ratio:	83 dB (Ref. 1Pa A-weighted)
Equivalent Noise Level:	11 dB (A-weighted IEC 651)
Max SPL for 0.5% THD:	152dB SPL
Power Requirements:	48V phantom power (+/- 4V)
Current Consumption:	6.6mA
Weight:	453.59g/1lb
Size:	50mm x 190mm/1.97 in. x 7.48 in.
Metal Finish:	Black chrome

MXL Cr-24p Instrument Microphone

Type:	Pressure gradient condenser mic
Diaphragm:	6-micron gold sputtered
Frequency Range:	30Hz-20kHz
Polar Pattern:	Cardioid
Sensitivity:	10mV/Pa
Impedance:	200 ohms
S/N Ratio:	80 dB (Ref. 1Pa A-weighted)
Equivalent Noise:	18 dB (A weighted IEC 268-4)
Max SPL for 0.5% THD:	134 dB SPL
Power Requirements:	48V phantom power (+/- 4V)
Current Consumption:	<3.0mA
Weight:	130g/0.29lbs
Size:	22mm x 135mm/0.87 in. x 5.31 in.
Metal Finish:	Black chrome

Polar Pattern

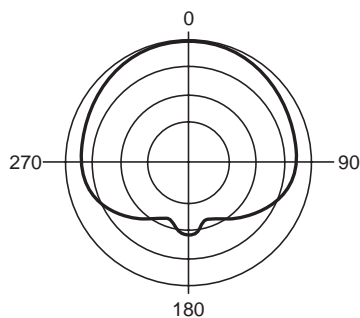

Cr-24 Frequency Chart

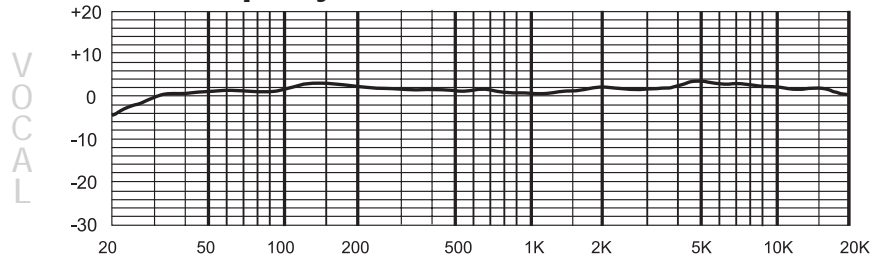

Polar Pattern

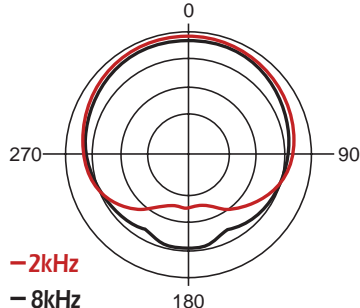

Cr-24p Frequency Chart

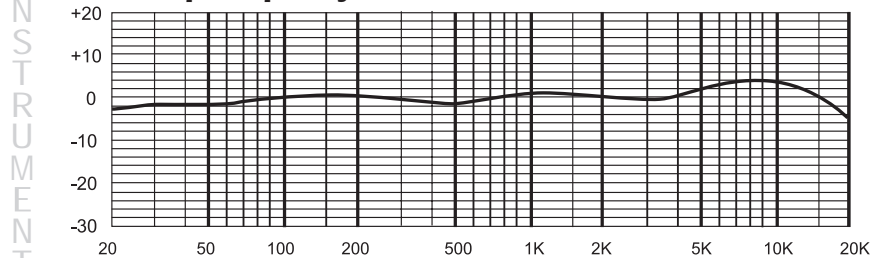

Warranty

Marshall microphones are guaranteed against defects in material and workmanship for three years from date of purchase. Should you encounter any problem with this unit, promptly contact the company you purchased it from for assistance. The original dated sales receipt will be necessary for any warranty claim. Do not send any unit directly to us without prior authorization from our service department! Warranty coverage is limited to repair or replacement (at our option) of the microphone, and does not cover incidental damages due to use of this unit, nor damage caused by accidental misuse of this product